









Read this instruction carefully. See hardware and furniture part list for guidance.
 Be sure all parts are complete before assembly. Place all wooden furniture parts on a clean and flat soft surface to prevent from being scratched.
 Follow the figure to start assembling.

CAUTION : 1. Do not FULLY - TIGHTEN the nuts or nuts bolts until they are ready for assembly.
 2. Do not OVER - TIGHTEN the nuts or bolts to avoid causing damages to the thread.
 3. Keep all hardware parts out of reach of children.

NOTE : THE LIST AND QUANTITY SHOWN ARE FOR 1 UNIT ASSEMBLY.

Tools needed : Screwdriver & Rubber Mallet (not provided).

PART LIST		
ITEM	DESCRIPTION	QTY
A	STOOL	1 PC
B	LEG	4 PCS
C	LEG SUPPORT (1)	1 PC
D	LEG SUPPORT (2)	2 PC
E	BOTTOM RAIL	1 PC

HARDWARE LIST		
ITEM	DESCRIPTION	QTY
1	JCBC BOLT M6 x 50mm 	8 PCS
2	JCBC BOLT M6 x 40mm 	1 PCS
3	M6 SPRING WASHER 	9 PCS
4	WOOD SCREW M4 x 45mm 	4 PCS
5	WOOD SCREW M4 x 38mm 	4 PCS
6	WOOD DOWEL M8 x 30mm 	4 PCS
7	SCREW CAP (BROWM) 	4 PCS
8	M4 ALLEN KEY (BALL SHAPE) 	1 PC

STEP 1

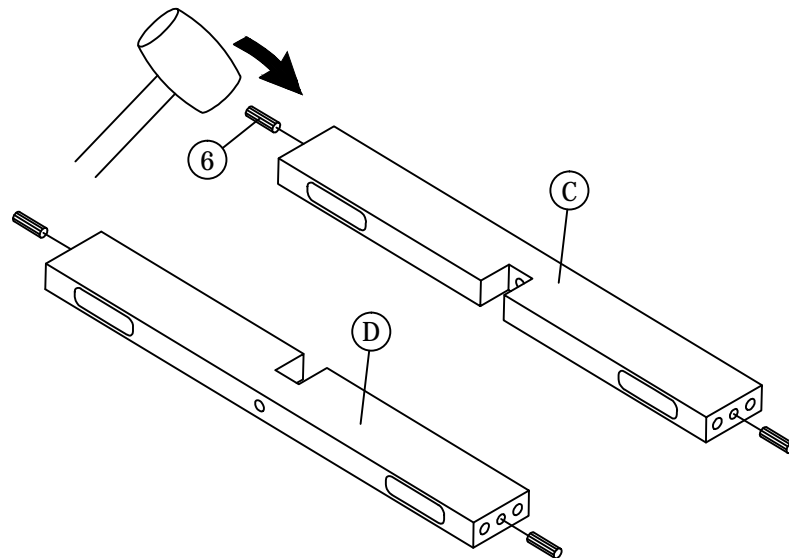

STEP 2

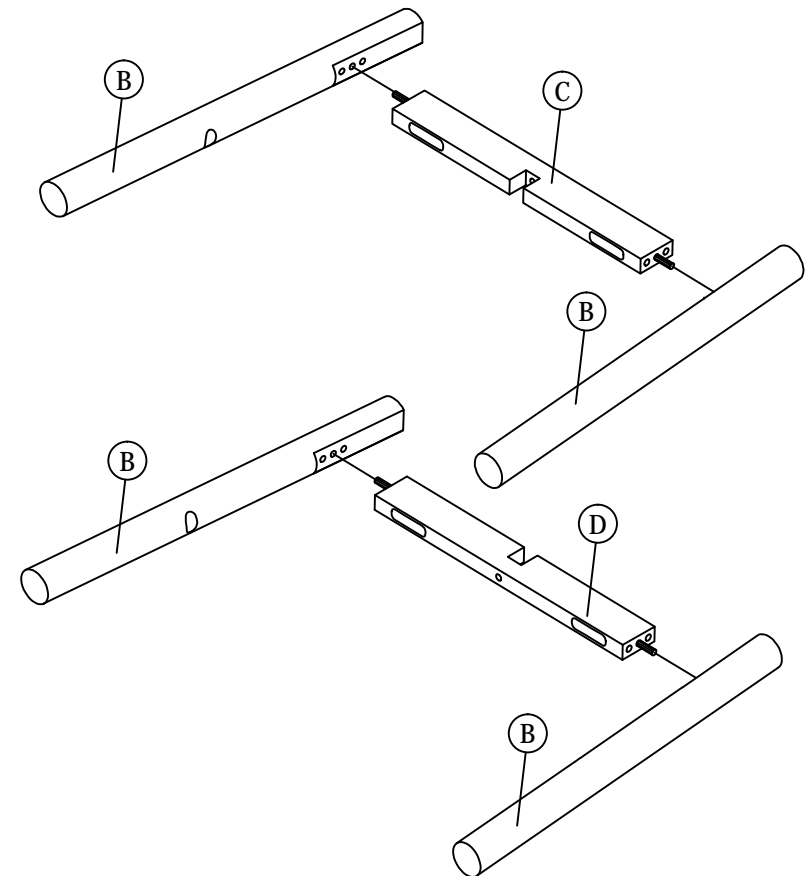

ASSEMBLY INSTRUCTIONS

STEP 3

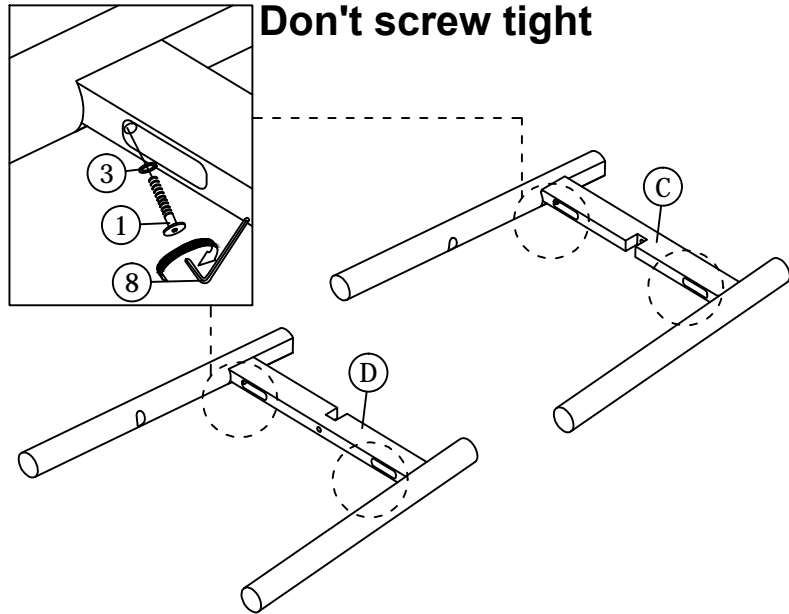

STEP 4

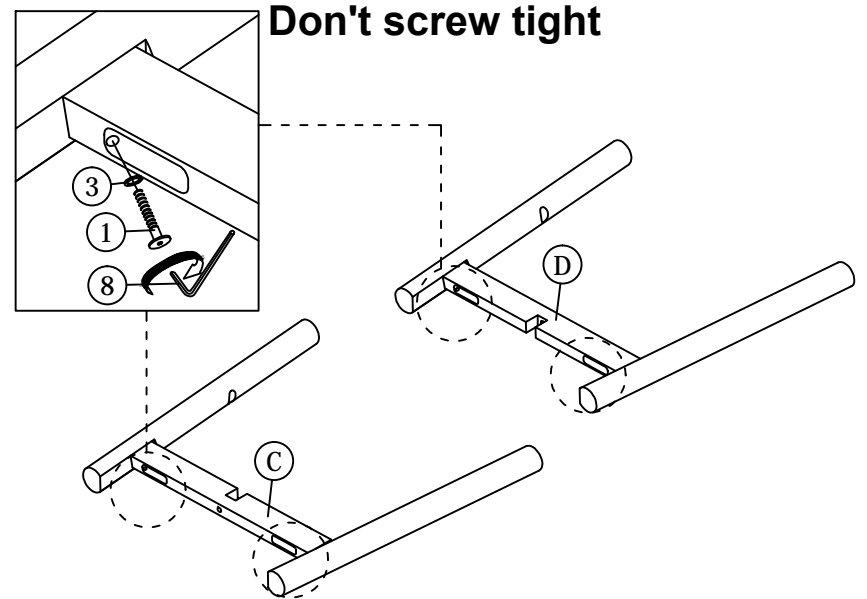

STEP 5

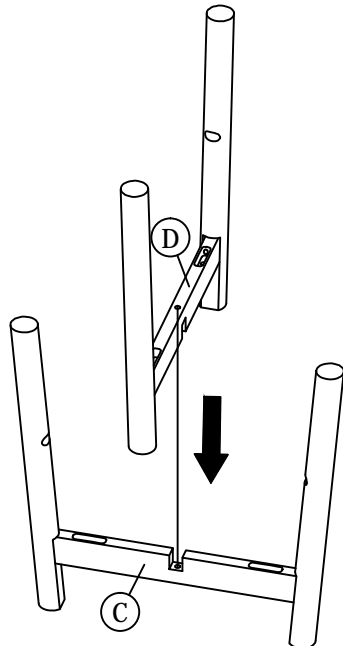

STEP 6

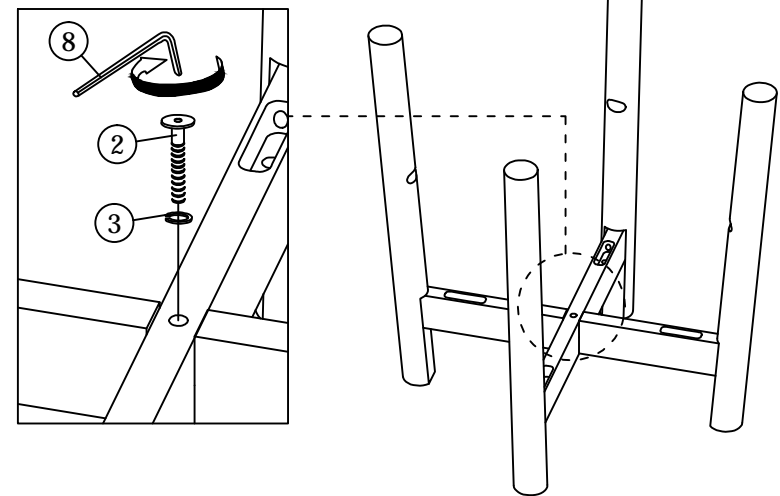

ASSEMBLY INSTRUCTIONS

STEP 7

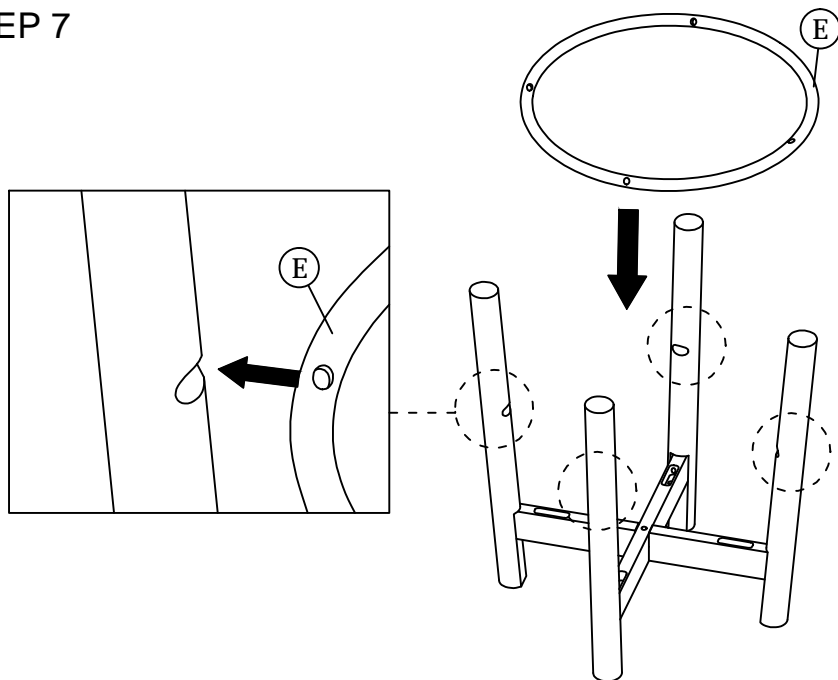

STEP 8

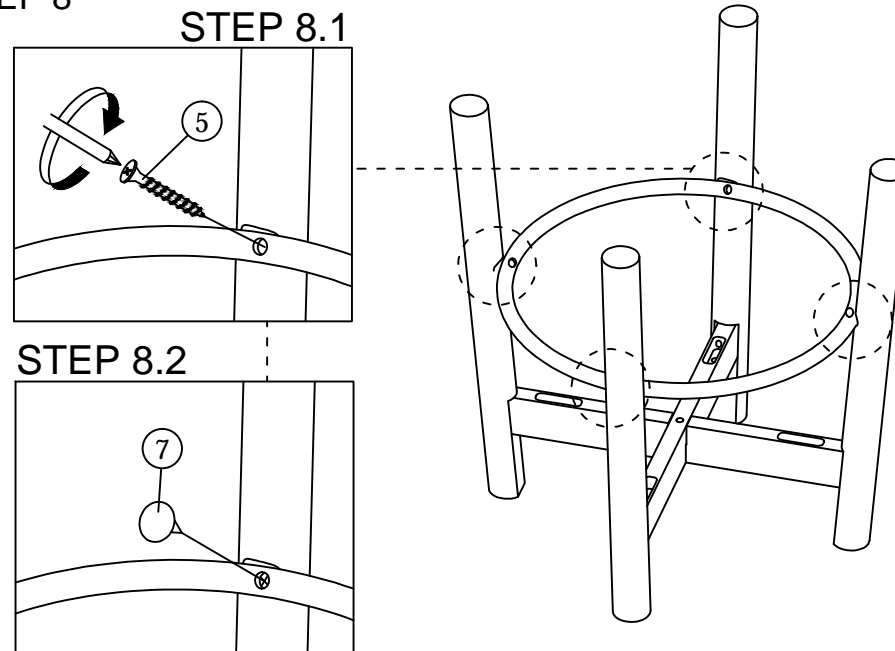

STEP 9

Place the chair on the flat surface and adjust the alignment and balance of the legs then , Please screw tight the steps 3 , 4 bolts.

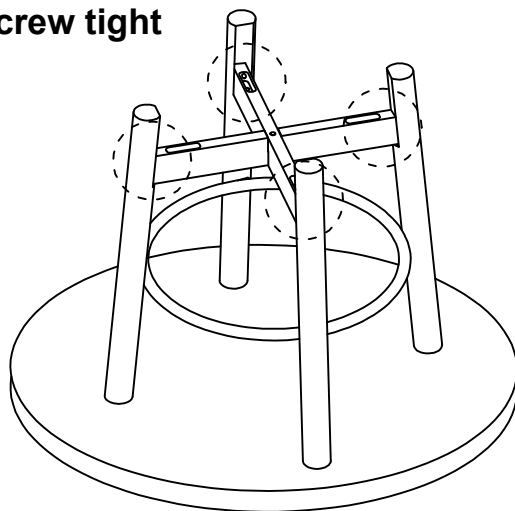

STEP 10

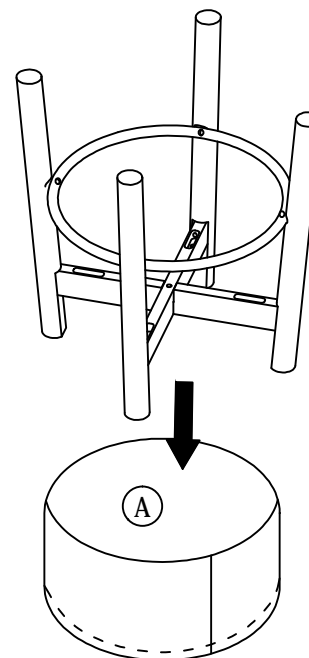

ASSEMBLY INSTRUCTIONS

STEP 11

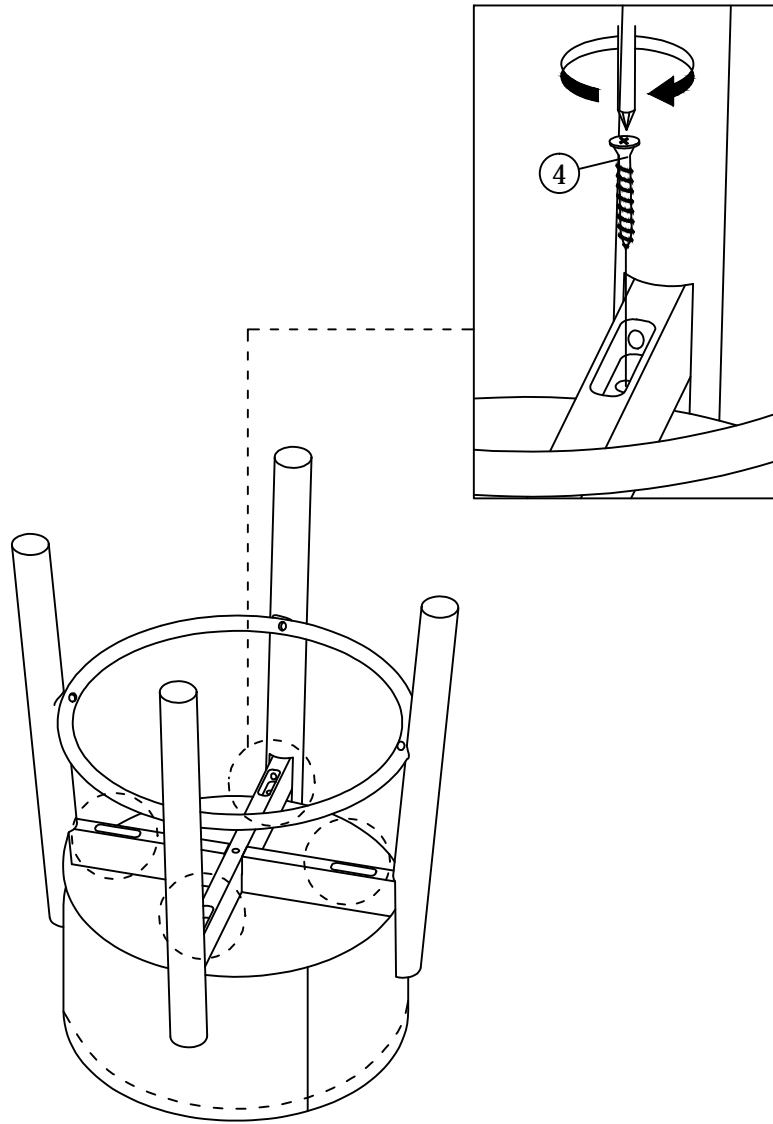

STEP 12

